

APPLICATION

Raked Bar Screen

OVERVIEW

The coarse screen lifts and removes large size debris using rakes and is supported by the embedded guide which is fixed in the concrete structure. The trash is then collected into the end side container.

At the 1st coarse screen, it not only protects the later part of fine screen but also the main pump. It often plays a crucial role in the whole screen process and determines the overall efficiency of the system.

There are 3 different types of coarse screens developed over the years. While each of them has its unique benefits, recently developed version of Moving Bar Screen (MBS) is widely used and preferred by most of the clients.

CONTROL

- A. Manual operation
- B. Semi-auto operation
- C. Automatic operation by differential water level across coarse screen and Sby periodic timer control

APPLICATION

Raked Bar Screen

Comparison of Coarse Screen

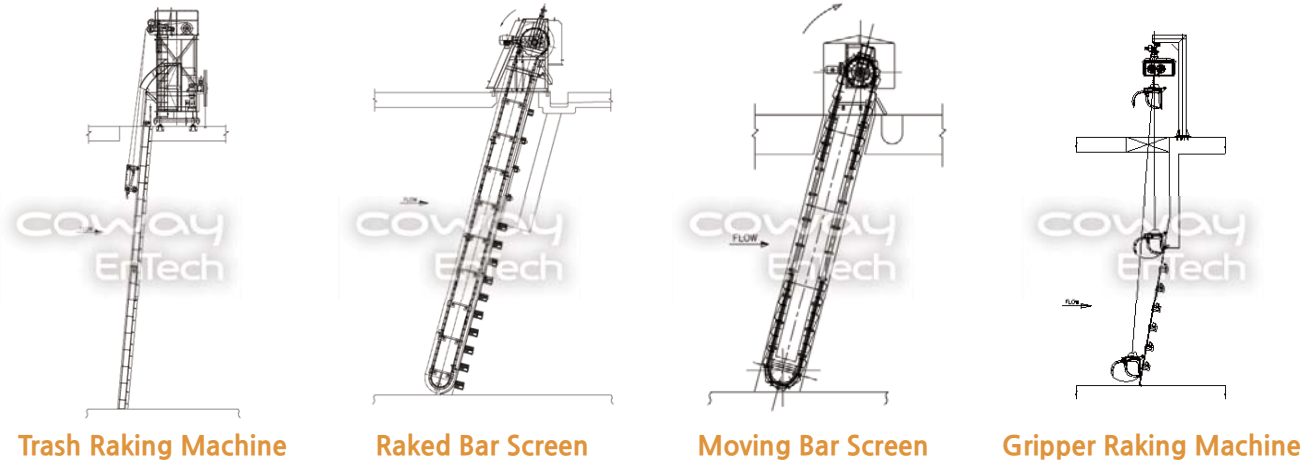

System Description	Fixed multiple bar screens on influent channels with one set of moving car type raking assembly, which traverses between channels	Fixed multiple bar screens equipped with rotating pitched on each influent channel	Bar screen panels rotate and remove debris continuously	A set of gripper raking machine travels several channels and removes debris from the bar screen.
Mechanical Structure	It is composed of hoisting unit, traversing unit, rake, frame, hydraulic cylinder, panel and cable reel. The rake is lowered until it reaches the bottom, then the rake is closed to pick up the trash. Collected trash is wasted to the hopper.	It is composed of flat bar screen, rakes, sprocket, chain, drive unit, and guide frame. Raking devices are attached at intervals to side end chains and these rakes travel to lift trash to the upper disposal trench.	It is composed of bar screen panel sprocket, chain, driving units, and debris thrusting rims. Bar screen panels are attached to every pitch of side end chains with a bucket. The trash is wasted by the thrusting rims pushing trash between bar screens into the trench.	Composed of hoisting unit, traversing unit, gripper, frame, hydraulic unit, control panel, festoon cable. Gripper travels along the channel until it reaches the bottom. It would then close the gripper teeth to grab the debris and dump it to the container.
Removal Efficiency	★★★ NOT BAD	★★★☆ GOOD	★★★★☆ EXCELLENT	★★★ Average
GET's suggestion	- For small volume of debris seawater project with low operation and construction expense	- For medium volume of debris with stable removal capability	- For large volume of debris with heavy load of jelly fish	- Suitable for large debris such as woods